

18.003 PRZELOTKA UNIWERSALNA
mocowana na wkręt samogwintujący M4, 8 x 25



18.131 UCHWYT PODPORY SŁUPKA POJEDYNCZY
(OCYNEK GALWANICZNY)
mocowana na wkręt samogwintujący 6, 3 x 25



18.132 UCHWYT PODPORY SŁUPKA PODWÓJNY
(OCYNEK GALWANICZNY)
mocowana na wkręt samogwintujący 2 x 6, 3 x 25



NASADKA SŁUPKA PODPOROWEGO

NR ART	D (mm)	C (mm)	H (mm)	h (mm)
18.142	∅ 42,4	54,8	54,8	54,8
18.148	∅ 48,3	60,9	60,9	60,9

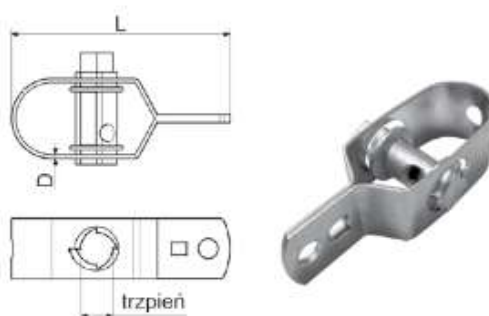

NACIĄG DO DRUTU (OCYNEK GALWANICZNY)

NR ART	TRZPIEŃ (mm)	D (mm)	L (mm)
18.150	∅14	1,5	90



ZŁĄCZE ZACISKOWE DO MOCOWANIA PANELI

NR ART	SŁUPEK (mm)
18.200 *	40 x 40
18.202 *	40 x 60

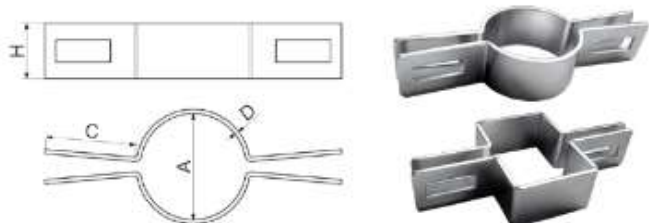

OBEJMA SŁUPKA - POŚREDNIA (OCYNEK GALWANICZNY)

NR ART	A (mm)	D (mm)	H (mm)	C (mm)
18.220	∅ 42	2,0	25,0	41,0
18.222	∅ 48	2,0	25,0	41,0
18.224	∅ 60	2,0	25,0	41,0
18.260	40 x 60	2,0	25,0	41,0

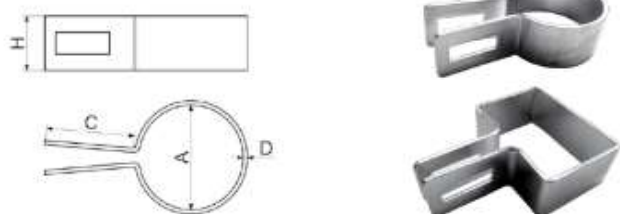

OBEJMA SŁUPKA - KOŃCOWA (OCYNEK GALWANICZNY)

NR ART	A (mm)	D (mm)	H (mm)	C (mm)
18.230	∅ 42	2,0	25,0	41,0
18.232	∅ 48	2,0	25,0	41,0
18.234	∅ 60	2,0	25,0	41,0
18.270	40 x 60	2,0	25,0	41,0

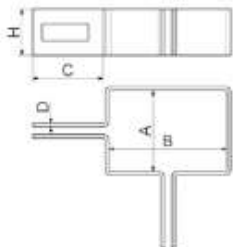

OBEJMA SŁUPKA - NAROŻNIKOWA (OCYNK GALWANICZNY)				
NR ART	A x B (mm)	D (mm)	H (mm)	C (mm)
18.280	40 x 60	2	25,0	41,0

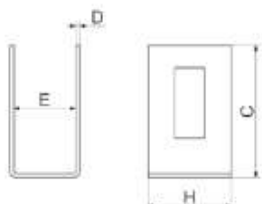

UCHWYT UNIWERSALNY (OCYNK GALWANICZNY)				
NR ART	D (mm)	H (mm)	C (mm)	E (mm)
18.325	2	25,0	41,0	14,0

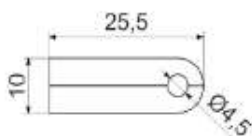
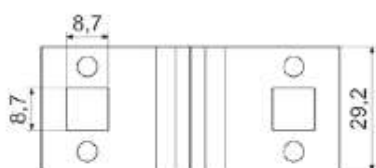

DYSTANS OBEJMY	
NR ART	DRUT (mm)
18.334	4
18.335	5



NR ART	18.347 ŚRUBA ZAMKOWA M8 X 20 z podkładką	18.350 KLIPS POMOOCNICZY	18.351 ZAPINKA	18.354 ZAPINKA 1/2	18.355 PODKŁADKA BLASZKOWA
--------	--	--------------------------------	-------------------	-----------------------	-------------------------------



TSG TULEJA STALOWA Z GWIEMEM				
ART. NR	∅ otw (mm)	ŚRUBA	L (mm)	pak (szt)
TSG 6	∅ 10	M 6	50	5
TSG 8	∅ 14	M 8	80	5
TSG 10	∅ 16	M 10	80	5
TSG 12	∅ 18	M 12	80	5



TSM TULEJA SIATKOWA METALOWA do kotwienia w pustych przestrzeniach				
ART. NR	∅ otw (mm)	ŚRUBA	L (mm)	pak (szt)
TSM 12	∅ 12	max M 8	1 000	5
TSM 16	∅ 16	max M 12	1 000	5
TSM 22	∅ 22	max M 16	1 000	5
TSM 26	∅ 26	max M 22	1 000	5



TSN TULEJA SIATKOWA NYLONOWA do kotwienia w pustych przestrzeniach				
ART. NR	∅ otw (mm)	ŚRUBA	L (mm)	pak (szt)
TSN 12.50	∅ 12	max M 8	50	4
TSN 12.80	∅ 12	max M 8	80	4
TSN 16.85	∅ 16	max M 12	85	4
TSN 16.135	∅ 16	max M 12	135	4
TSN 20.85	∅ 20	max M 16	85	4